

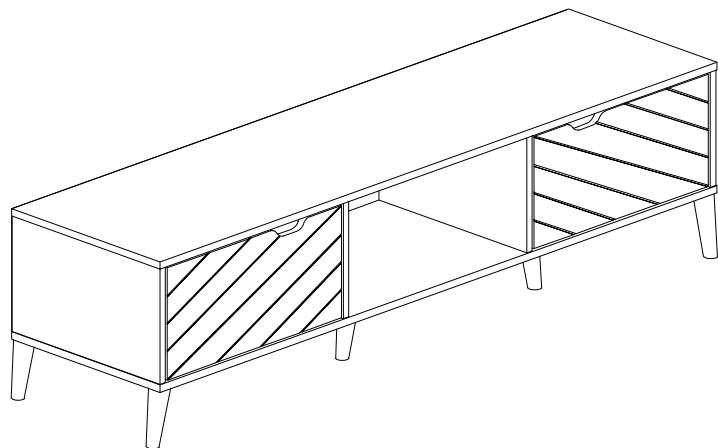





Assembly Instruction

049-000099



Hardware List			
No.	SHAPE	DESCRIPTION	Qty.
A		8x25mm Dowel	16Pcs
B		15MM Myfix Minifix	8Sets
C		M3.5x16mm Screw	38Pcs
D		M4x45mm Screw	8Pcs
E		2 Pin Magnet	2Sets
F		MT Stopper	4Pcs
G		Round Taper Leg 150mm	6Pcs
H		6/8 Power Pin	30Pcs

Part List

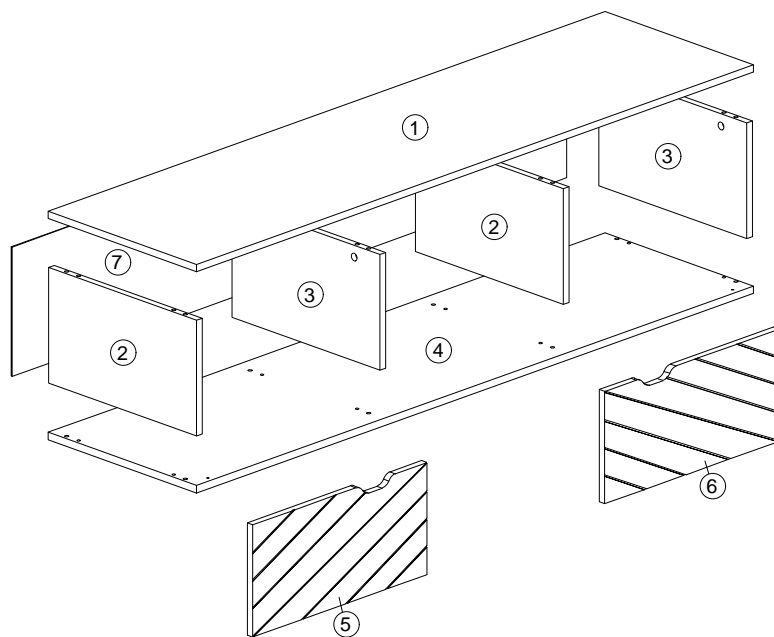

Assembly Instruction

Step 1

A		8x25mm Dowel	16Pcs
---	---	--------------	-------

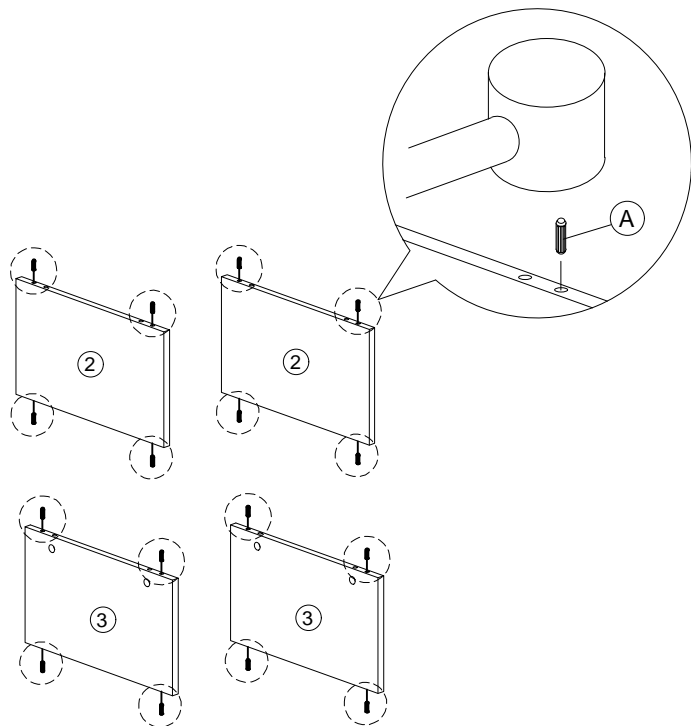

Step 2

E		2 Pin Magnet	2Pcs
---	---	--------------	------

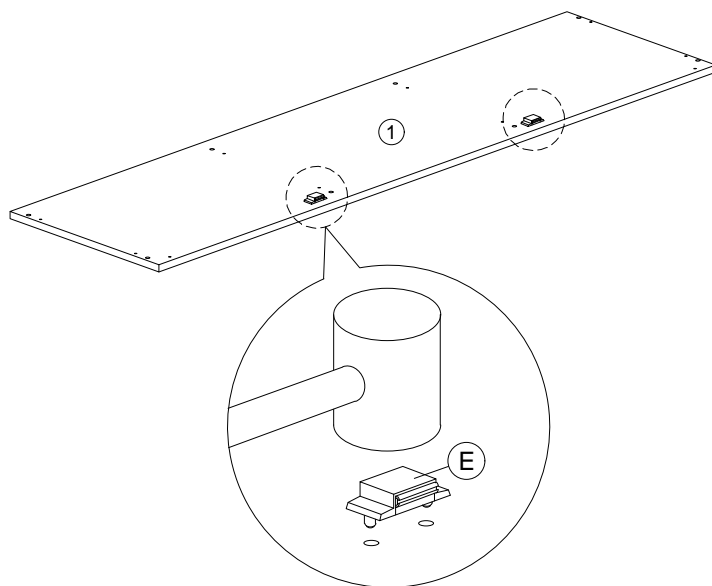

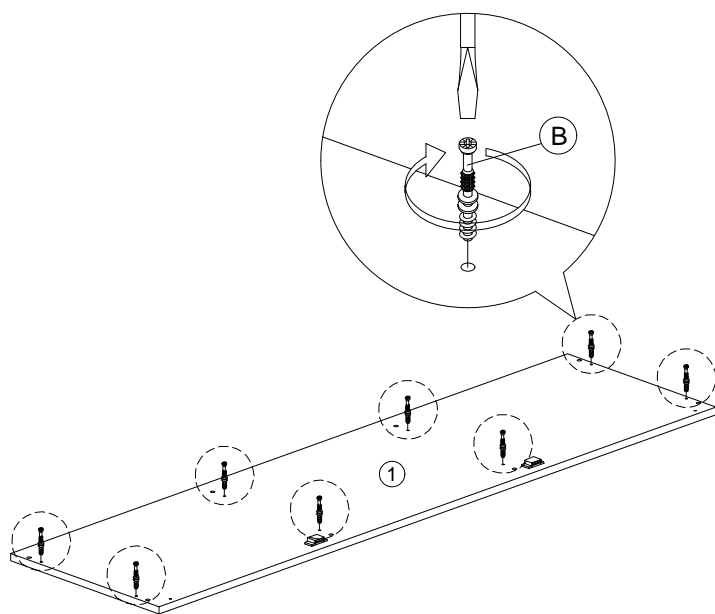

Step 3

B		Myfix	8Pcs
---	---	-------	------



Step 4

C		M3.5x16mm Screw	24Pcs
G		Round Taper Leg 150mm	6Pcs

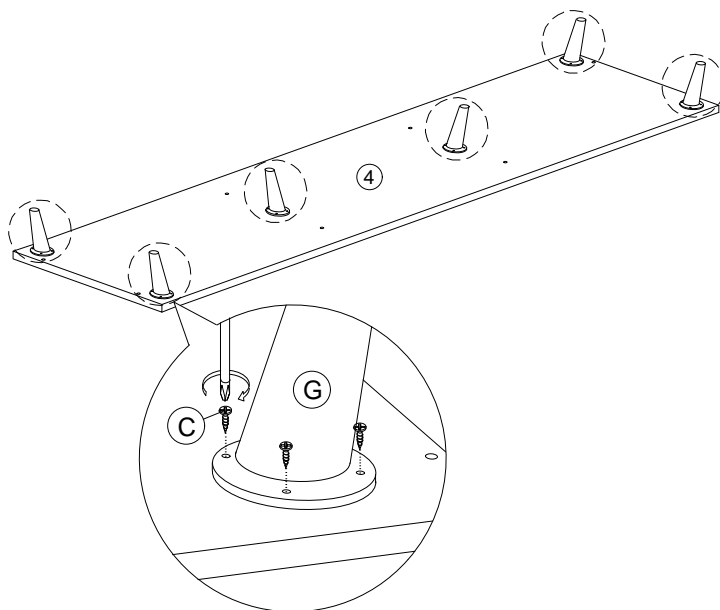

Assembly Instruction

Step 5

D		M4x45mm Screw	8Pcs
---	---	---------------	------

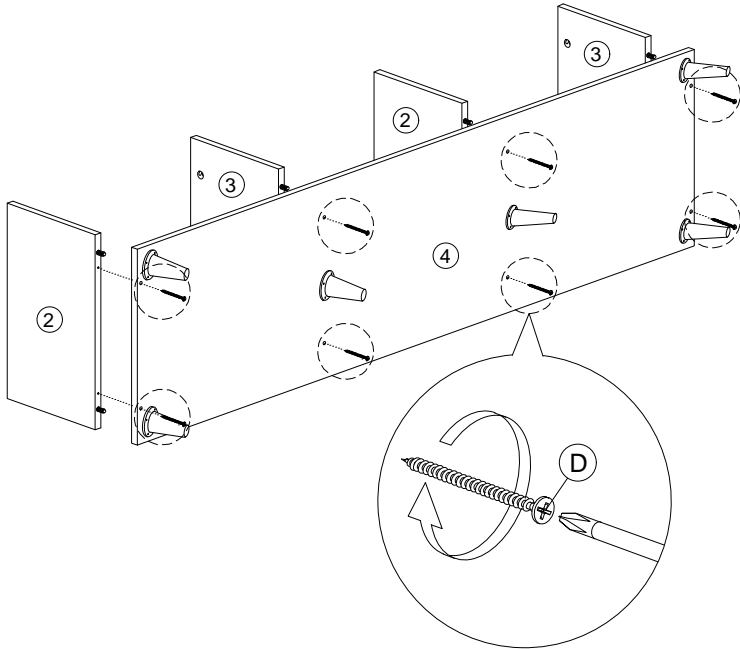

Step 6

B		Minifix	8Pcs
---	---	---------	------

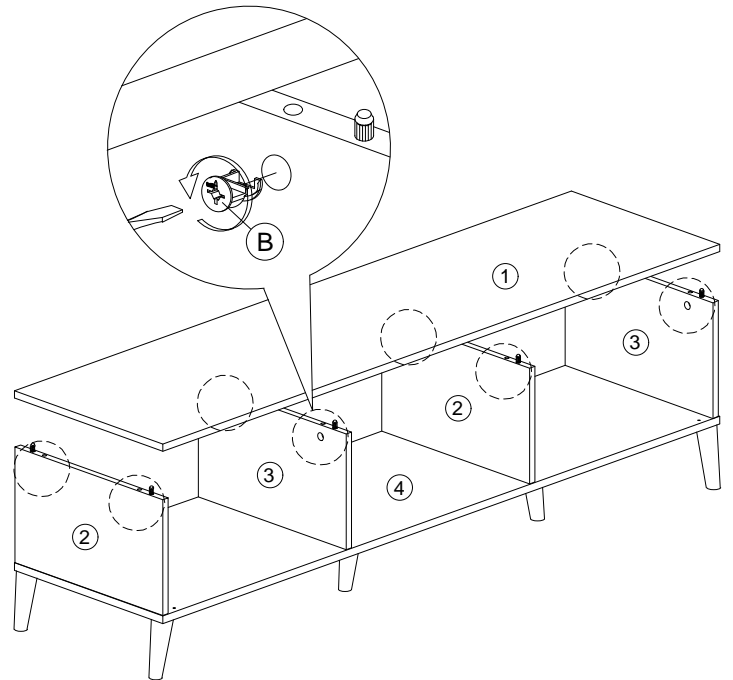

Step 7

H		6/8 Power Pin	30Pcs
---	---	---------------	-------

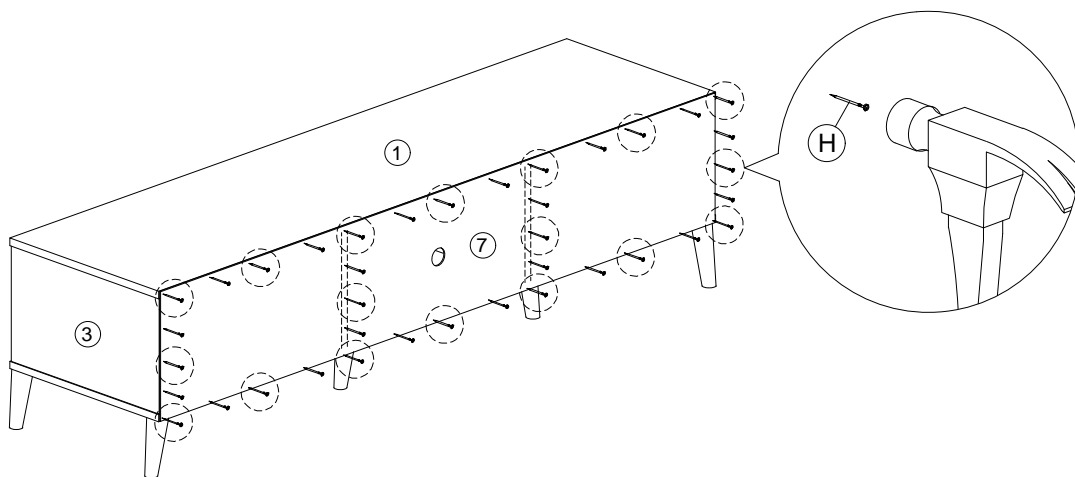

Assembly Instruction

Step 8

F		MT Stopper	2Pcs
---	---	------------	------

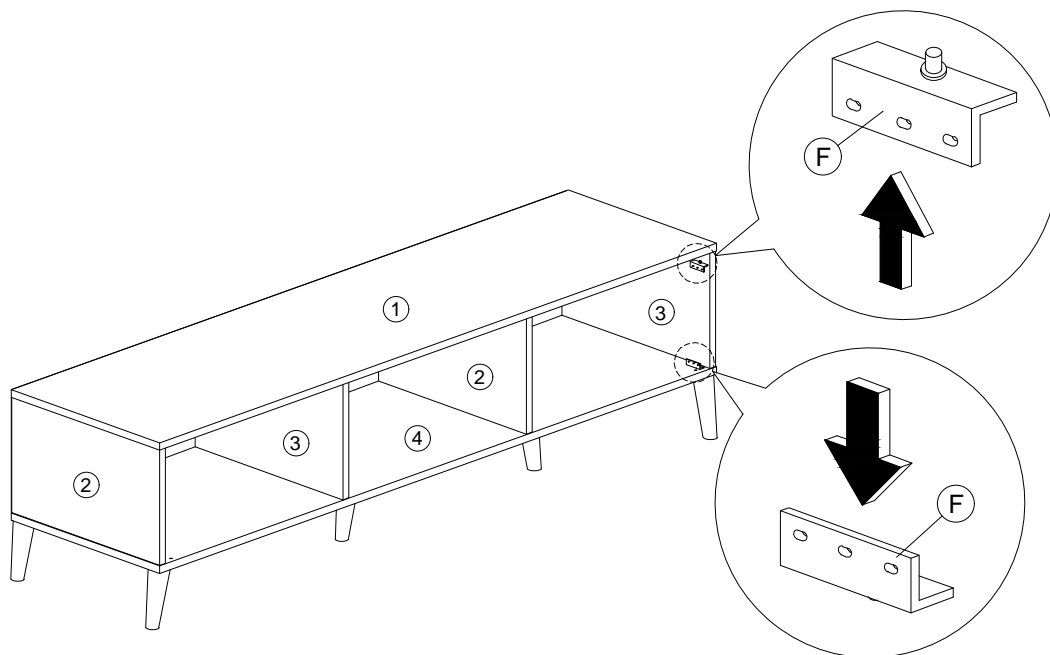

Step 9

C		M3.5x16mm Screw	6Pcs
---	---	-----------------	------

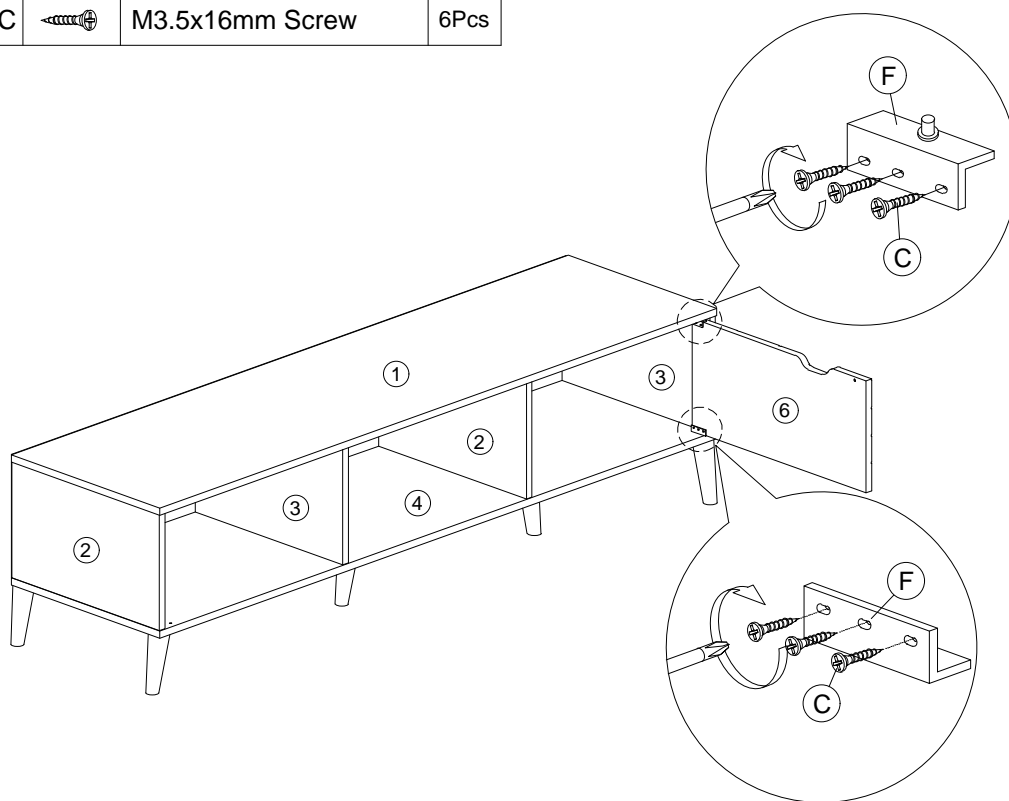

Assembly Instruction

Step 10

C		M3.5x16mm Screw	1Pc
---	---	-----------------	-----

E		2 Pin Magnet	1Pc
---	---	--------------	-----

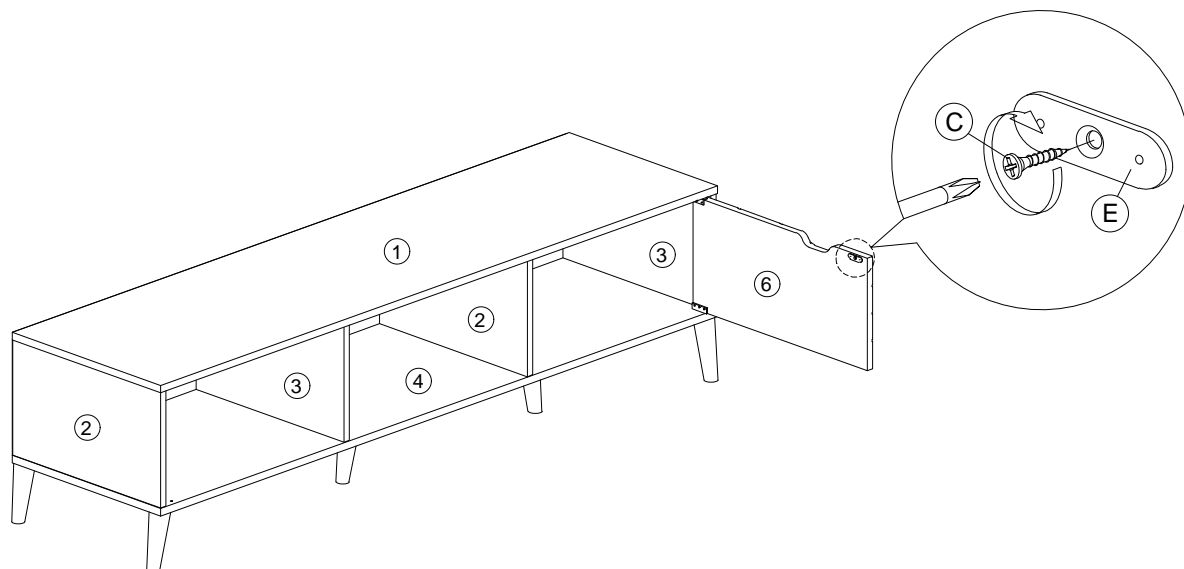

Step 11

F		MT Stopper	2Pcs
---	---	------------	------

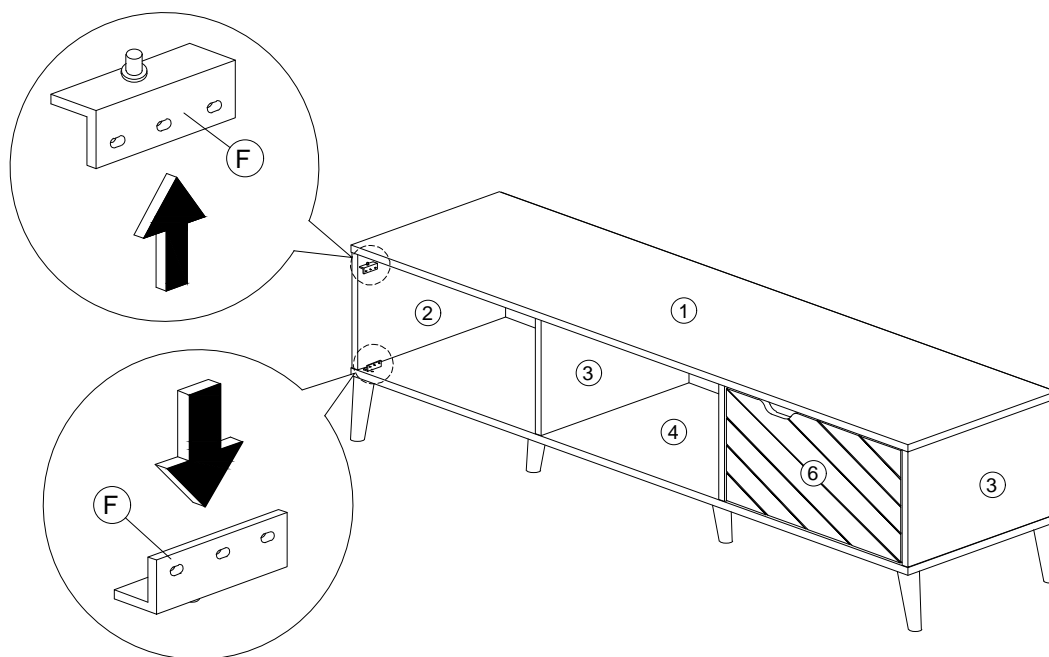

Assembly Instruction

Step 12

C		M3.5x16mm Screw	6Pcs
---	---	-----------------	------

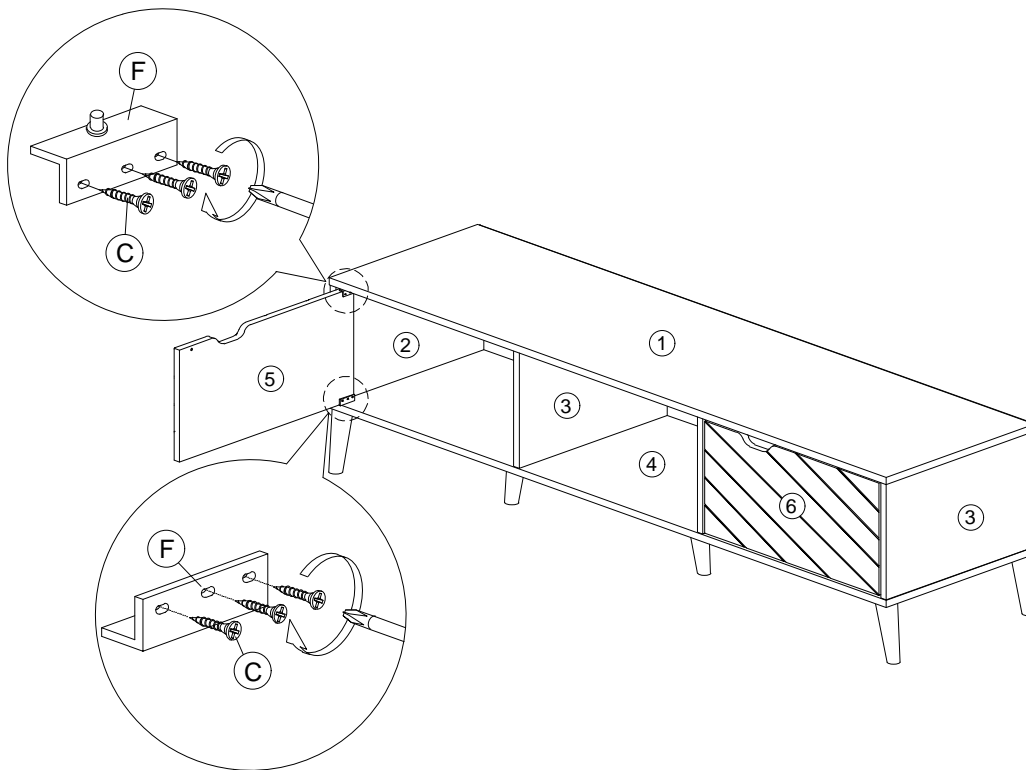

Step 13

C		M3.5x16mm Screw	1Pc
---	---	-----------------	-----

E		2 Pin Magnet	1Pc
---	---	--------------	-----

