

CAUTION:

To clean use soft, dry cloth. Do not use detergent or chemicals
Avoid contact with water and direct sunlight.
To be assembled on a soft, dry, clean and smooth surface.

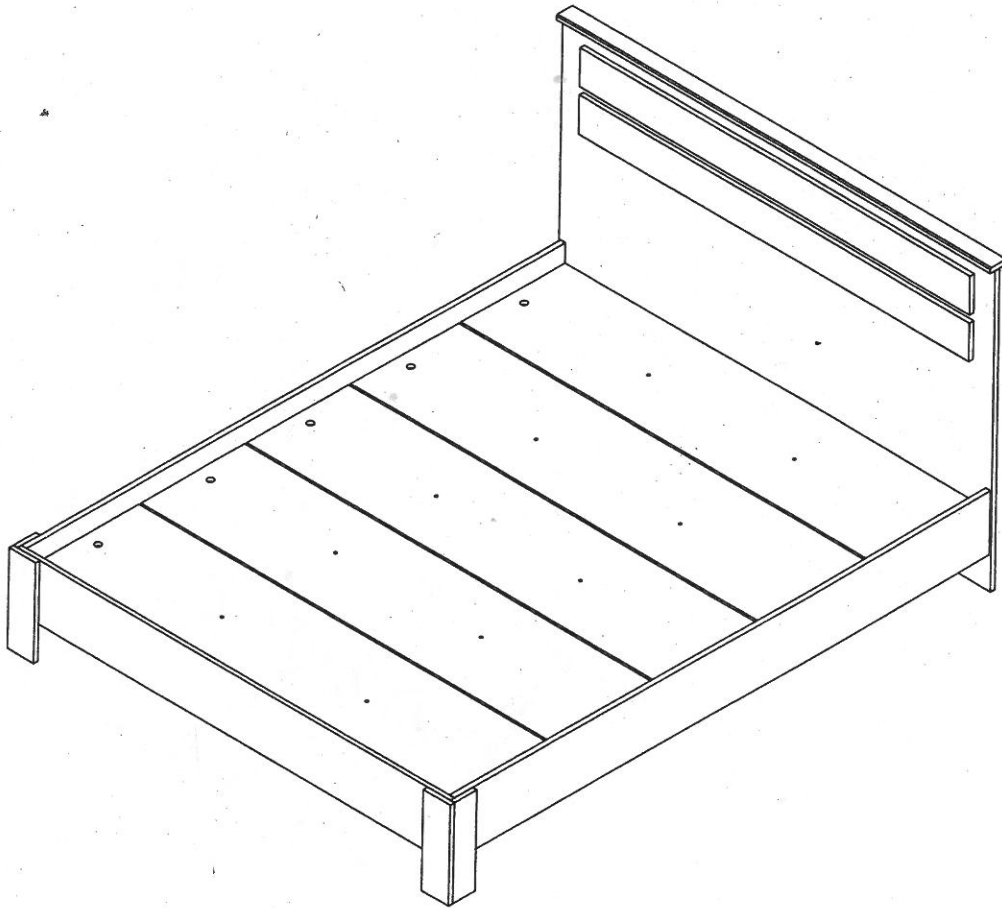

COMPLETE SET

ORDERING REPAIR PARTS

In order to obtain smooth and rapid service when ordering repair parts,
please give full attention to the following of PART NUMBER.

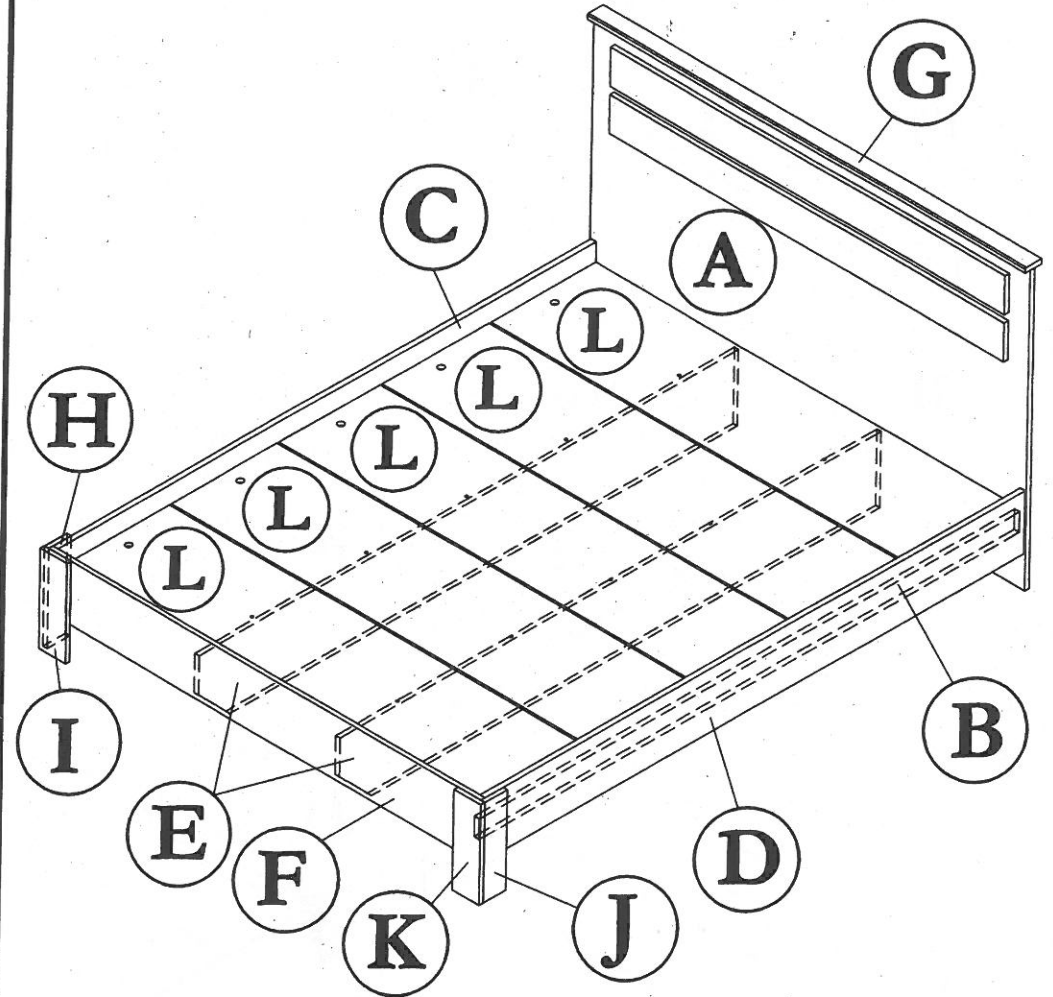

NO	DESCRIPTION	QTY
A	BACK VERTICAL	01
B	SIDE SUPPORT	02
C	LEFT SIDE	01
D	RIGHT SIDE	01
E	CENTRE VERTICAL	02
F	FRONT VERTICAL	01
G	WRAPPING	01

NO	DESCRIPTION	QTY
H	LEFT SIDE VERTICAL	01
I	FRONT VERTICAL	01
J	RIGHT SIDE VERTICAL	01
K	FRONT VERTICAL	01
L	DECORATIVE BOARD	05

ASSEMBLY INSTRUCTION

MODEL : 4853 DB / DOUBLE BED

Before you begin, please follow assembly instruction carefully.
Then follow them step by step.

STEP 1

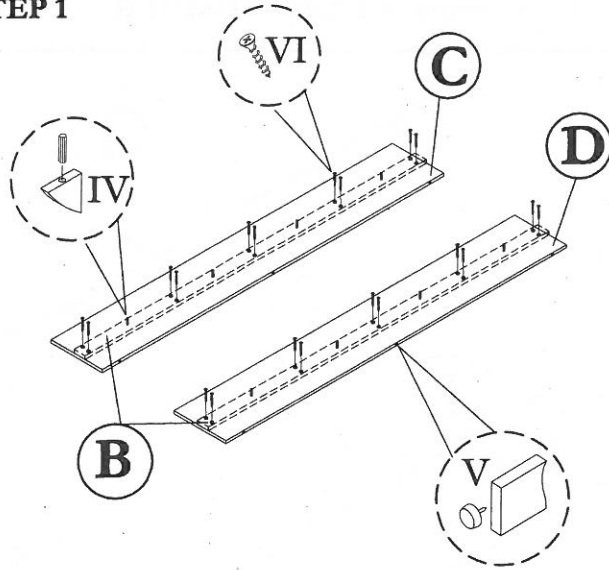

STEP 2

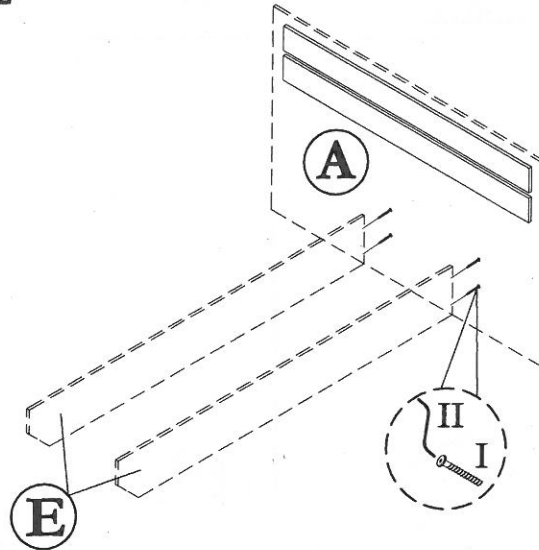

STEP 3

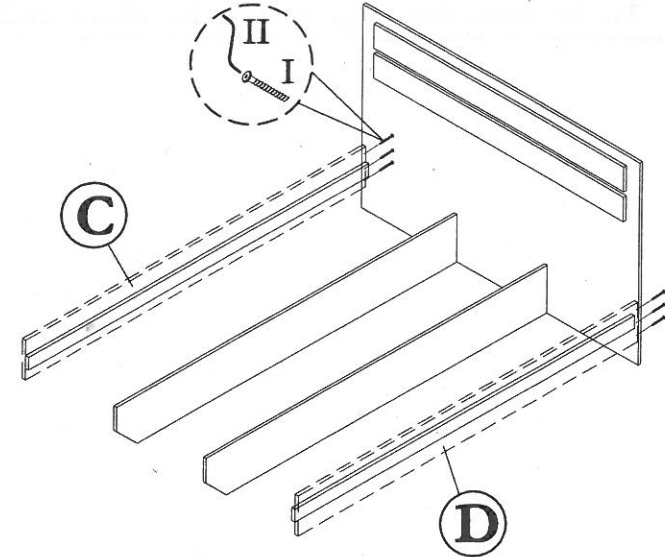

STEP 4

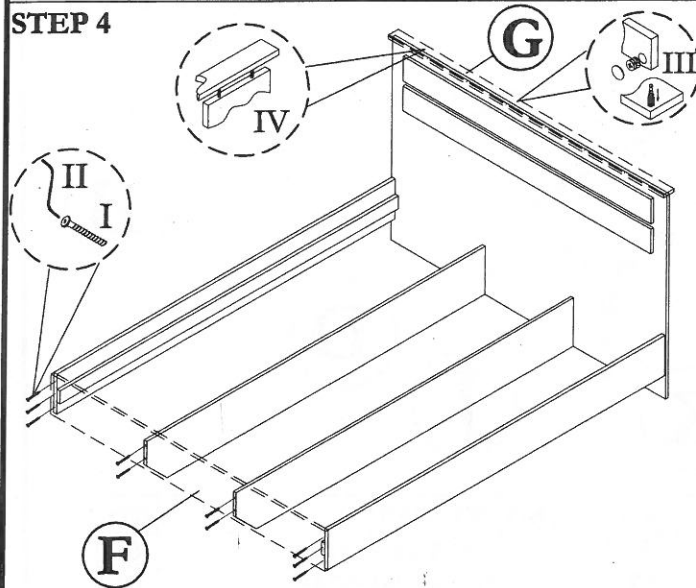

STEP 5

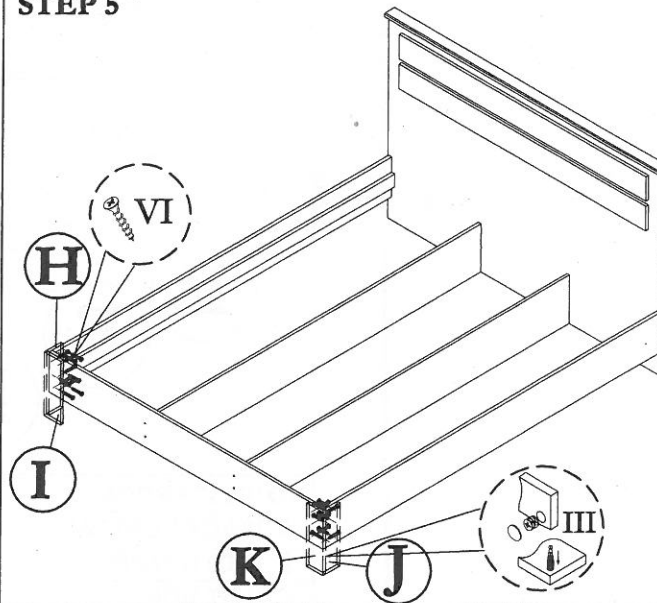

STEP 6

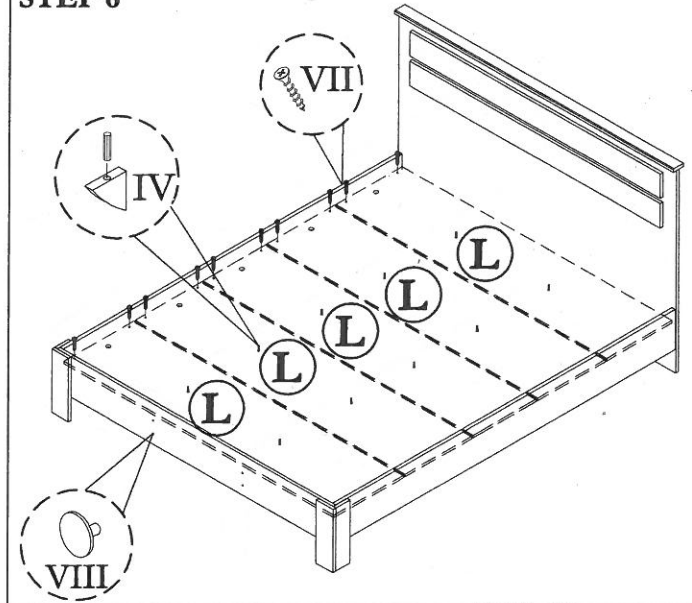

HARDWARE LIST			
NO	DESCRIPTION		QTY
I	JCBCW SCREW M6 x 60		20pcs
II	M4 ALLEN KEY		1pc

III	Q-FIT, CAP-2PCS		5sets
IV	M8 x 30 PLASTIC DOWEL		22pcs
V	PVC NAIL WITH PIN		13pcs
VI	M3.5 x 30 CHIPBOARD SCREW		46pcs

VII	M4 x 25 CHIPBOARD SCREW		20pcs
VIII	CAP SMALL		14pcs