





HARDWARE ITEM		QTY
F2	 Mini Fix 15mm	28 Sets
L1	 Leg Pin	6
R9	 Plastic Round Wire Cap	2
Y	 Mini Fix Plastic Cap	16

COMPLETE

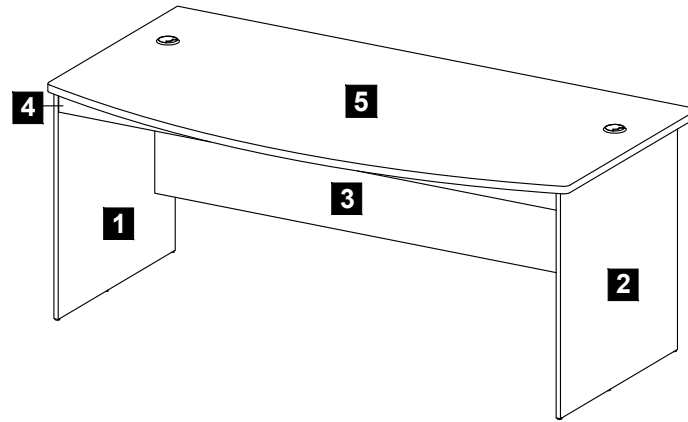

PRE - ASSEMBLY

STEP 1 Insert the Mini Fix Cam (F2) at panel no. 1, 2, 3 & 4. Then, insert the Mini Fix Bolt (F2) & Leg Pin (L1) at panel no. 1 & 2.

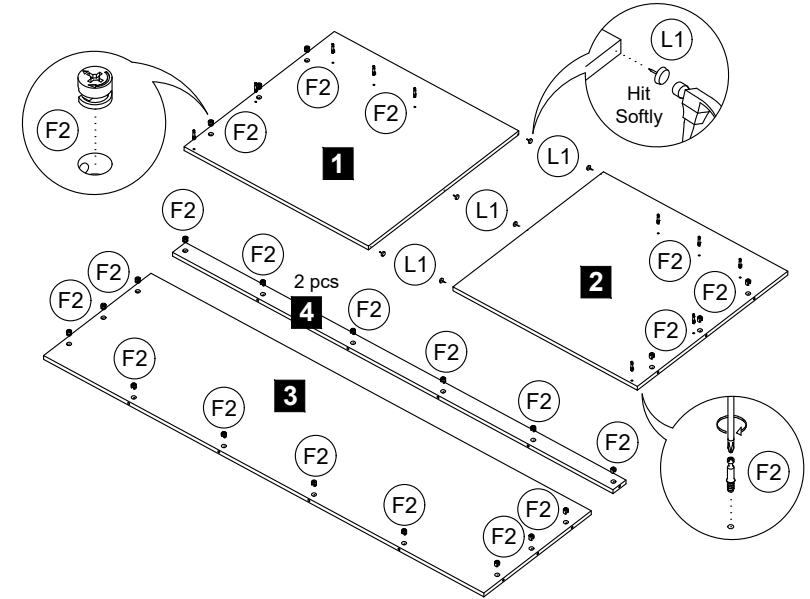

STEP 2 Insert the Mini Fix Bolt (F2) at panel no. 5.

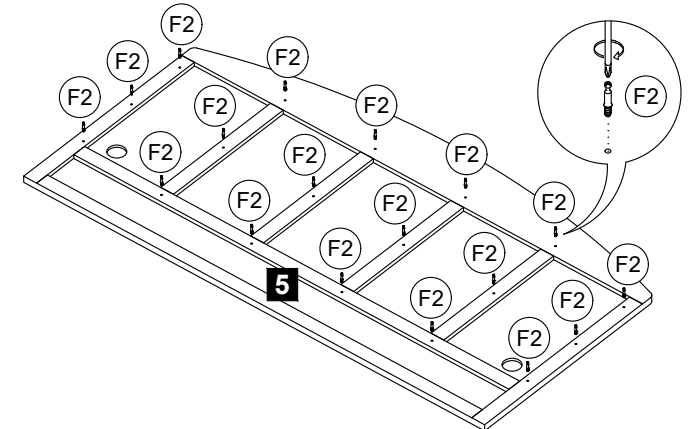

CAUTION

MATERIAL USE LAMINATED PARTICLE BOARD, TO CLEAN USE SOFT, DRY CLOTH. DO NOT USE DETERGENT OR CHEMICAL AVOID CONTACT WITH WATER AND DIRECT SUNLIGHT. TO BE ASSEMBLED ON A SOFT, DRY, CLEAN SMOOTH SURFACE.

USE OF POWER TOOLS TO ASSEMBLE THIS PRODUCT WILL INVALIDATE ANY CLAIM AND MAY DAMAGE THIS PRODUCT MAKING IT UNSAFE.



STEP 3 Assemble the panel no. 1, 2, 3 & 4 together by using Mini Fix 15mm (F2) and button the Mini Fix Cam (F2) with Mini Fix Plastic Cap (Y) except for panel no. 4.

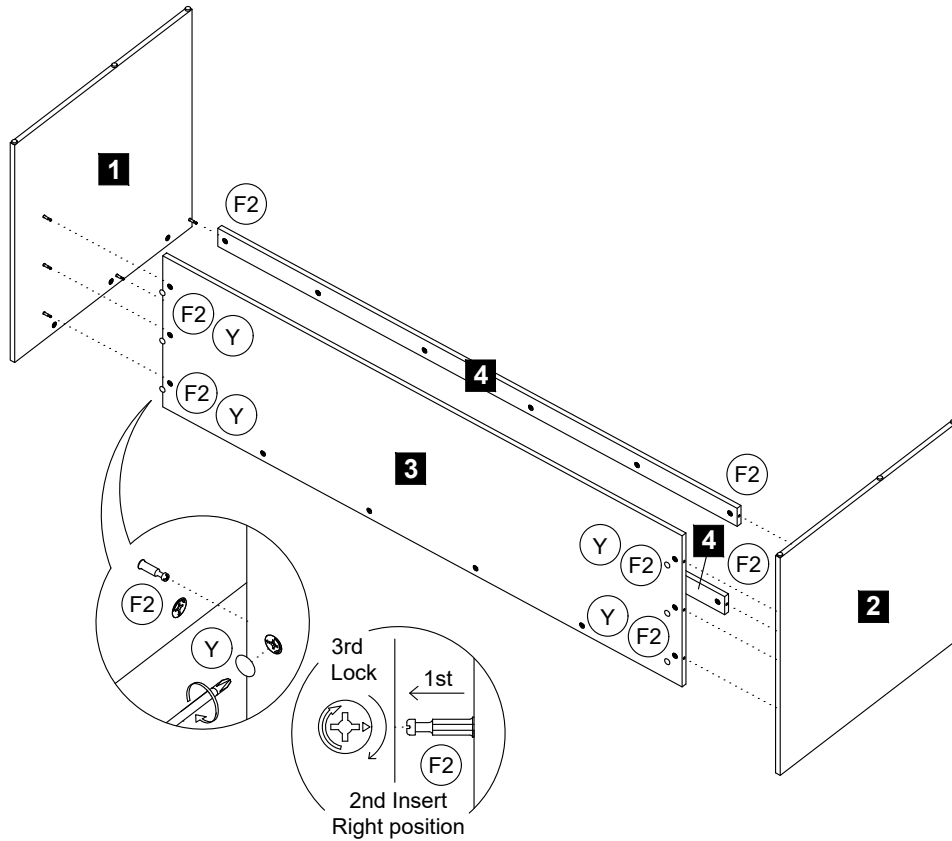

STEP 4 Assemble the panel no. 5 to the unit by using Mini Fix 15mm (F2) and button the Mini Fix Cam (F2) with Mini Fix Plastic Cap (Y) except for panel no. 4. Then, insert the Plastic Round Wire Cap (R9) at panel no. 5.

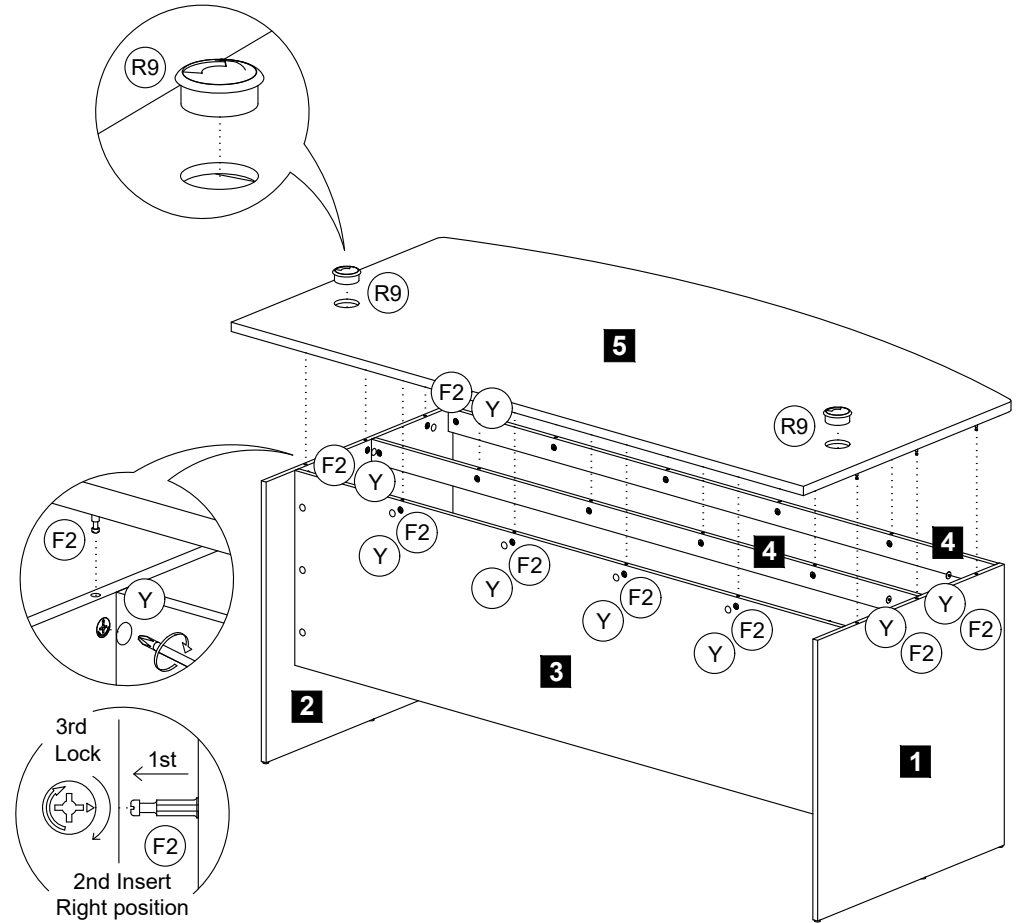

Flip Up